

LOW INPUT VOLTAGE, CAP FREE 150-mA LOW-DROPOUT LINEAR REGULATORS

FEATURES

- 150-mA LDO
- Available in 1.5-V, 1.6-V, 1.8-V Fixed-Output and Adjustable (1.2-V to 2.5-V) Versions
- Low Input Voltage Requirement (Down to 1.8 V)
- Small Output Capacitor, 0.1- μ F
- Dropout Voltage Typically 200 mV at 150 mA
- Less Than 1 μ A Quiescent Current in Shutdown Mode
- Thermal Protection
- Over Current Limitation
- 5-Pin SOT-23 (DBV) Package

APPLICATIONS

- Portable Communication Devices
- Battery Powered Equipment
- PCMCIA Cards
- Personal Digital Assistants
- Modems
- Bar Code Scanners
- Backup Power Supplies
- SMPS Post Regulation
- Internet Audio

DESCRIPTION

The TPS721xx family of LDO regulators is available in fixed voltage options that are commonly used to power the latest DSPs and microcontrollers with an adjustable option ranging from 1.22 V to 2.5 V. These regulators can be used in a wide variety of applications ranging from portable, battery-powered equipment to PC peripherals. The family features operation over a wide range of input voltages (1.8 V to 5.5 V) and low dropout voltage (150 mV at full load). Therefore, compared to many other regulators that require 2.5-V or higher input voltages for operation, these regulators can be operated directly from two AAA batteries. Also, the typical quiescent current (ground pin current) is low, starting at 85 μ A during normal operation and 1 μ A in shutdown mode. These regulators can be operated very efficiently and, in a battery-powered application, help extend the longevity of the device.

Similar LDO regulators require 1- μ F or larger output capacitors for stability. However, this regulator uses an internal compensation scheme that stabilizes the feedback loop over the full range of input voltages and load currents with output capacitances as low as 0.1- μ F. Ceramic capacitors of this size are relatively inexpensive and available in small footprints.

This family of regulators is particularly suited as a portable power supply solution due to its minimal board space requirement and 1.8-V minimum input voltage. Being able to use two off-the-shelf AAA batteries makes system design easier and also reduces component cost. Moreover, the solution will be more efficient than if a regulator with a higher input voltage is used.

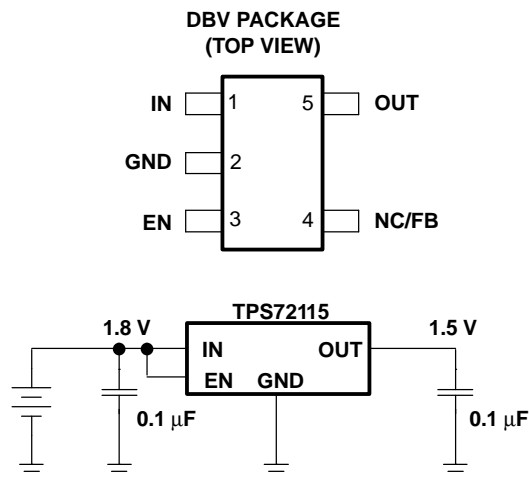

Please be aware that an important notice concerning availability, standard warranty, and use in critical applications of Texas Instruments semiconductor products and disclaimers thereto appears at the end of this data sheet.



These devices have limited built-in ESD protection. The leads should be shorted together or the device placed in conductive foam during storage or handling to prevent electrostatic damage to the MOS gates.

ORDERING INFORMATION

T _J	VOLTAGE	PACKAGE	PART NUMBER		SYMBOL
-40°C to 125°C	Adjustable	SOT-23 (DBV)	TPS72101DBVT ⁽¹⁾	TPS72101DBVR ⁽²⁾	PEKI
	1.5 V		TPS72115DBVT ⁽¹⁾	TPS72115DBVR ⁽²⁾	PEII
	1.6 V		TPS72116DBVT ⁽¹⁾	TPS72116DBVR ⁽²⁾	PHFI
	1.8 V		TPS72118DBVT ⁽¹⁾	TPS72118DBVR ⁽²⁾	PEJI

- (1) The DBVT indicates tape and reel of 250 parts.
(2) The DBVR indicates tape and reel of 3000 parts.

ABSOLUTE MAXIMUM RATINGS

over operating free-air temperature range unless otherwise noted⁽¹⁾⁽²⁾

	TPS72101, TPS72115, TPS72116, TPS72118
Voltage range at IN	-0.3 V to 7 V
Voltage range at EN	-0.3 V to 7 V
Voltage on OUT, FB, NC	-0.3 V to V _I + 0.3 V
Peak output current	Internally limited
ESD rating, HBM	3 kV
Continuous total power dissipation	See Dissipation Rating Table
Operating junction temperature range, T _J	-40°C to 150°C
Storage temperature range, T _{stg}	-65°C to 150°C

- (1) Stresses beyond those listed under *absolute maximum ratings* may cause permanent damage to the device. These are stress ratings only, and functional operation of the device at these or any other conditions beyond those indicated under *recommended operating conditions* is not implied. Exposure to absolute-maximum-rated conditions for extended periods may affect device reliability. All voltage values are with respect to network ground terminal.
(2) All voltage values are with respect to network ground terminal.

PACKAGE DISSIPATION RATING

BOARD	PACKAGE	R _{θJC}	R _{θJA}	DERATING FACTOR ABOVE T _A = 25°C	T _A ≤ 25°C POWER RATING	T _A = 70°C POWER RATING	T _A = 85°C POWER RATING
Low-K ⁽¹⁾	DBV	65.8 °C/W	259 °C/W	3.9 mW/°C	386 mW	212 mW	154 mW
High-K ⁽²⁾	DBV	65.8 °C/W	180 °C/W	5.6 mW/°C	555 mW	305 mW	222 mW

- (1) The JEDEC Low-K (1s) board design used to derive this data was a 3 inch x 3 inch, two-layer board with 2 ounce copper traces on top of the board.
(2) The JEDEC High-K (2s2p) board design used to derive this data was a 3 inch x 3 inch, multilayer board with 1 ounce internal power and ground planes and 2 ounce copper traces on top and bottom of the board.

ELECTRICAL CHARACTERISTICS

over recommended operating junction temperature range $V_{IN} = V_{OUT(Nom)} + 1\text{ V}$, $I_{OUT} = 1\text{ mA}$, $EN = V_{IN}$, $C_{OUT} = 1\text{ }\mu\text{F}$ (unless otherwise noted)

PARAMETER		TEST CONDITIONS		MIN	TYP	MAX	UNIT
V_{IN}	Input voltage ⁽¹⁾			1.8		5.5	V
V_{OUT}	Output voltage range	TPS72101		1.225		2.5	V
I_{OUT}	Continuous output current			0		150	mA
T_J	Operating junction temperature			-40		125	°C
V_{OUT}	Output voltage	TPS72101	$0\text{ }\mu\text{A} < I_{OUT} < 150\text{ mA}^{(1)}$ $1.8\text{ V} \leq V_{OUT} \leq 2.5\text{ V}$ $T_J = 25^\circ\text{C}$			$0.97 V_O$ 1.5	$1.03 V_O$
		TPS72115	$0\text{ }\mu\text{A} < I_{OUT} < 150\text{ mA}$ $2.5\text{ V} \leq V_{IN} \leq 5.5\text{ V}$ $T_J = 25^\circ\text{C}$			1.455	1.545
		TPS72116	$0\text{ }\mu\text{A} < I_{OUT} < 150\text{ mA}$ $2.6\text{ V} \leq V_{IN} \leq 5.5\text{ V}$ $T_J = 25^\circ\text{C}$			1.552	1.648
		TPS72118	$0\text{ }\mu\text{A} < I_{OUT} < 150\text{ mA}$ $2.8\text{ V} \leq V_{IN} \leq 5.5\text{ V}$ $T_J = 25^\circ\text{C}$			1.746	1.854
$I_{(Q)}$	Quiescent current (GND current)		$T_J = 25^\circ\text{C}$		85		μA
				$I_{OUT} = 150\text{ mA}$ $T_J = 25^\circ\text{C}$		570	
				$I_{OUT} = 150\text{ mA}$		850	
	Standby current		$EN < 0.5\text{ V}$ $T_J = 25^\circ\text{C}$		0.01		μA
			$EN < 0.5\text{ V}$			1	
V_n	Output noise voltage	TPS72115	$BW = 200\text{ Hz to } 100\text{ kHz}$, $T_J = 25^\circ\text{C}$ $C_o = 1\text{ }\mu\text{F}$		90		μV
V_{ref}	Reference voltage		$T_J = 25^\circ\text{C}$		1.225		V
PSRR	Ripple rejection		$f = 100\text{ Hz}$, $C_o = 10\text{ }\mu\text{F}$, $I_{OUT} = 150\text{ mA}$ $T_J = 25^\circ\text{C}$; See (1)		48		dB
	Current limit		See (2)		175	525	mA
	Output voltage line regulation ($\Delta V_{OUT}/V_{OUT}$) ⁽¹⁾		$V_O + 1\text{ V} < V_{IN} \leq 2.5\text{ V}$ $T_J = 25^\circ\text{C}$		0.03	0.09	%V
						0.1	
	Output voltage load regulation	TPS72118	$0 < I_{OUT} < 150\text{ mA}$ $T_J = 25^\circ\text{C}$		0.5		mV
V_{IH}	EN high level input			1.4			V
V_{IL}	EN low level input			-0.2		0.4	
I_I	EN input current		$EN = 0\text{ V}$		-0.01		μA
			$EN = IN$		-0.01		
V_{DO}	Dropout voltage ⁽³⁾	TPS72118	$I_{OUT} = 150\text{ mA}$ $T_J = 25^\circ\text{C}$		150		mV
		TPS72101	$I_{OUT} = 150\text{ mA}$ $1.2\text{ V} \leq V_O \leq 5.2\text{ V}$			240	
I_n	Feedback input current	TPS72101				1	μA
	Thermal shutdown temperature				170		°C
	Thermal shutdown hysteresis				20		°C

(1) Minimum IN operating voltage is 1.8 V or $V_{OUT} + V_{DO}$, whichever is greater.

(2) Test condition includes output voltage $V_O = 1\text{ V}$ and pulse duration = 10 mS.

(3) Dropout voltage is defined as the differential voltage between V_O and V_I when V_O drops 100 mV below the value measured with $V_{IN} = V_{OUT} + V_{DO}$.

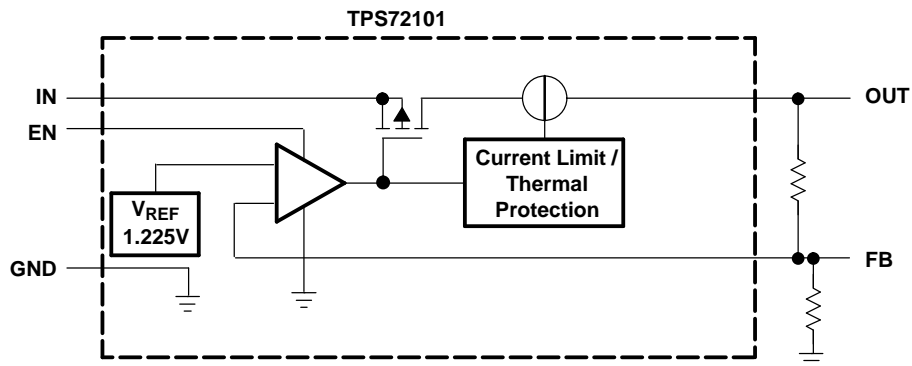
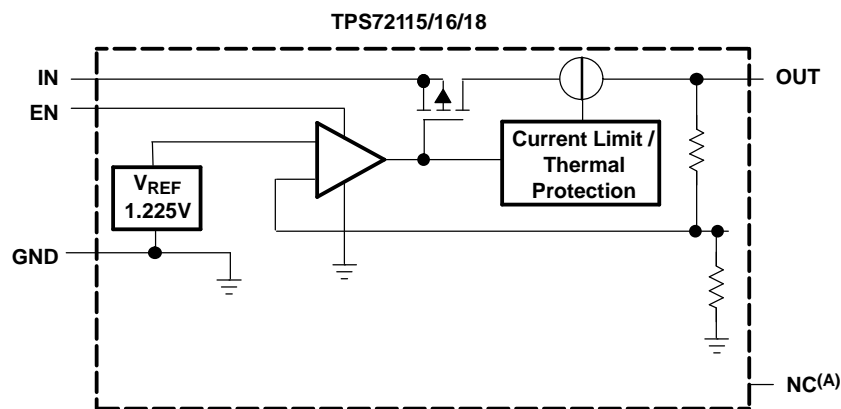

Figure 1. FUNCTIONAL BLOCK DIAGRAM—ADJUSTABLE VERSION



A. This pin must be left floating and not connected to GND.

Figure 2. FUNCTIONAL BLOCK DIAGRAM—FIXED VERSION

Terminal Functions

TERMINAL NAME	NO.	DESCRIPTION
GND	2	Ground
EN	3	Enable input
IN	1	Input supply voltage
NC/FB	4	NC = Not connected (see (A)); FB = Feedback (adjustable option TPS72101)
OUT	5	Regulated output voltage

TYPICAL CHARACTERISTICS

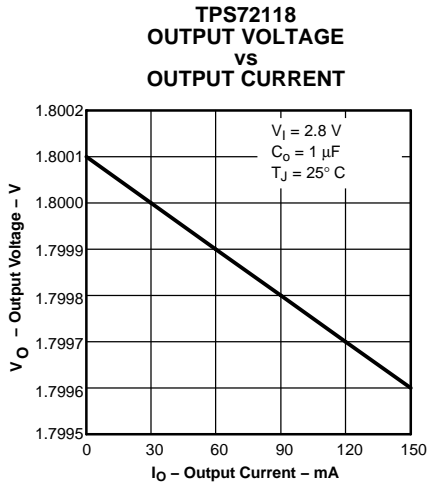

Figure 3.

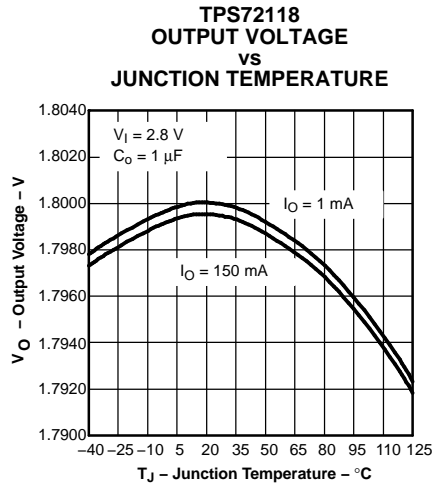

Figure 4.

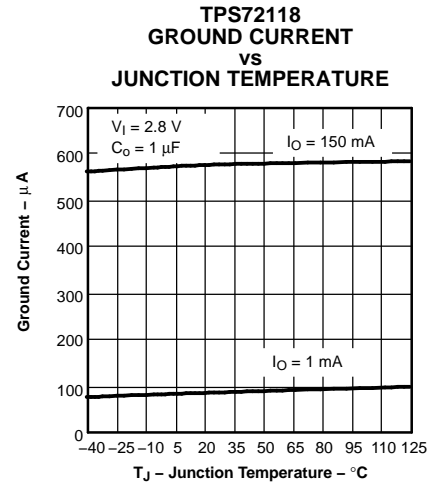

Figure 5.

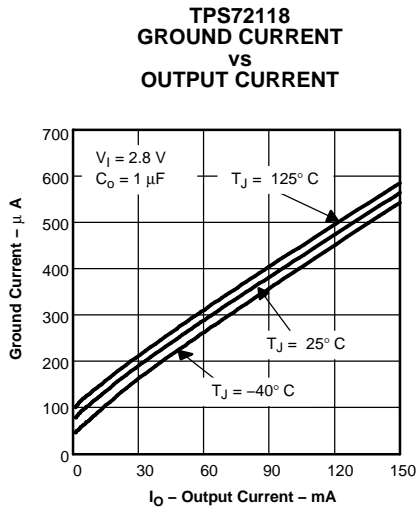

Figure 6.

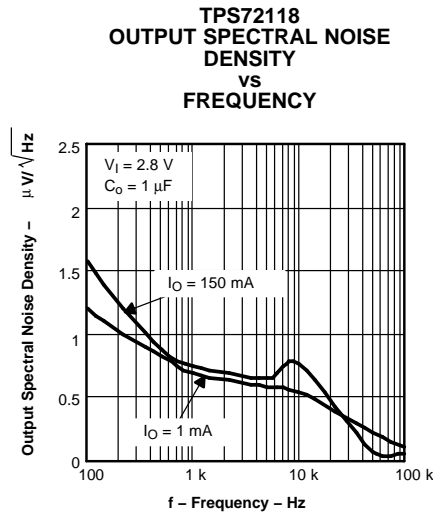

Figure 7.

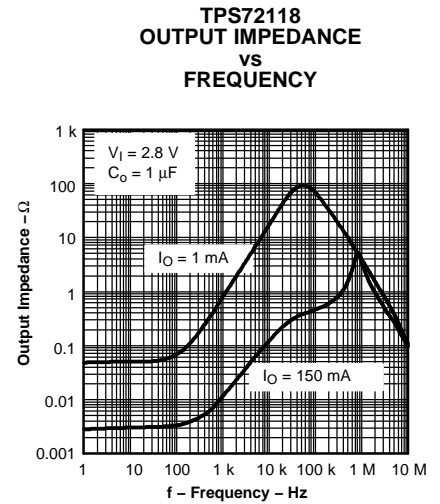

Figure 8.

TYPICAL CHARACTERISTICS (continued)

TPS72118
DROPOUT VOLTAGE
VS
JUNCTION TEMPERATURE

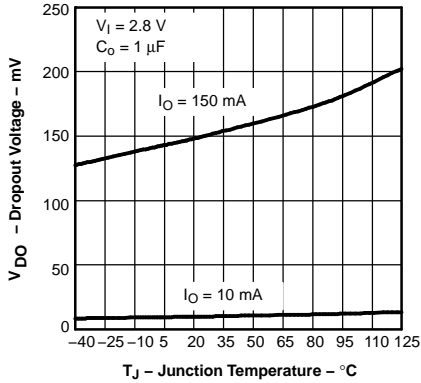

Figure 9.

TPS72118
POWER SUPPLY RIPPLE
REJECTION
VS
FREQUENCY

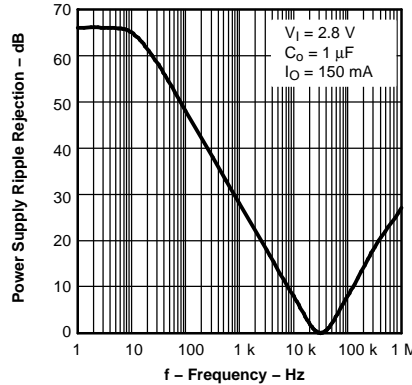

Figure 10.

TPS72118
OUTPUT VOLTAGE, ENABLE
VOLTAGE
VS
TIME (START-UP)

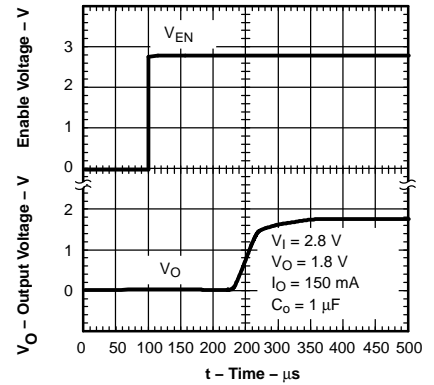

Figure 11.

TPS72118
LINE TRANSIENT RESPONSE

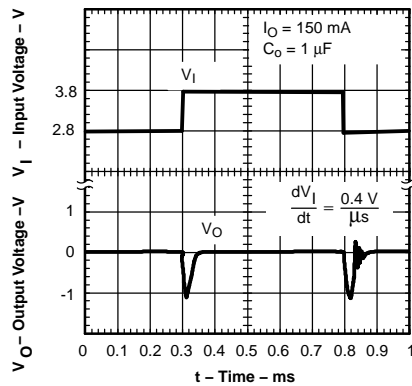

Figure 12.

TPS72118
LOAD TRANSIENT RESPONSE

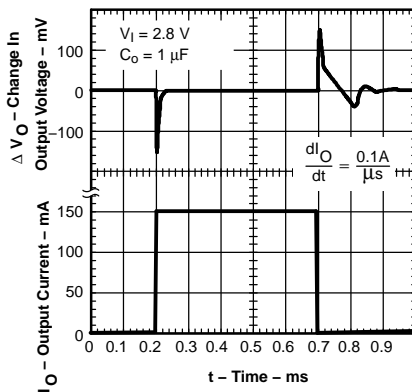

Figure 13.

POWER UP / POWER DOWN

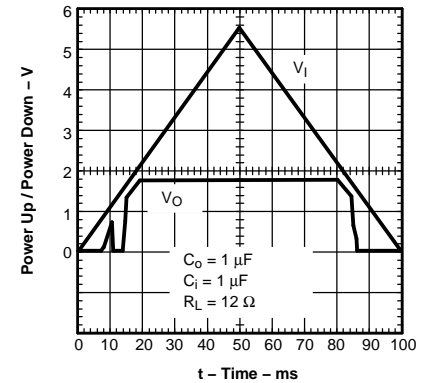

Figure 14.

DC DROPOUT VOLTAGE
VS
OUTPUT CURRENT

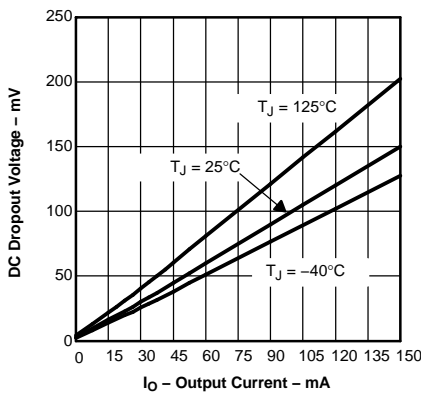

Figure 15.

TPS72101
DROPOUT VOLTAGE
VS
INPUT VOLTAGE

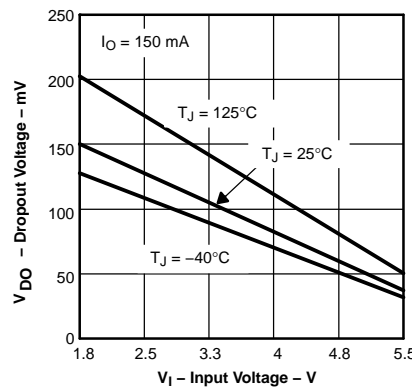

Figure 16.

MINIMUM REQUIRED INPUT
VOLTAGE
VS
OUTPUT VOLTAGE

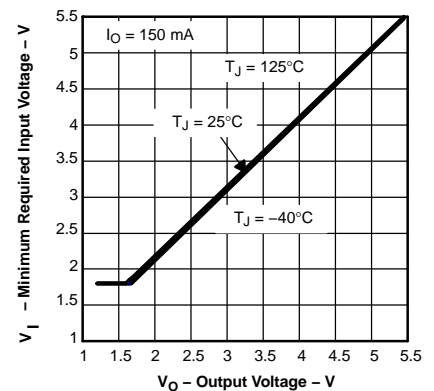

Figure 17.

APPLICATION INFORMATION

The TPS721xx family of low-dropout (LDO) regulators functions with a very low input voltage (>1.8 V). The dropout voltage is typically 150 mV at full load. Typical quiescent current (ground pin current) is only 85 μ A and drops to 1 μ A in the shutdown mode.

DEVICE OPERATION

The TPS721xx family can be operated at low input voltages due to low voltage circuit design techniques and a PMOS pass element that exhibits low dropout.

A logic low on the enable input, EN, shuts off the output and reduces the supply current to less than 1 μ A. EN may be tied to V_{IN} in applications where the shutdown feature is not used.

Current limiting and thermal protection prevent damage by excessive output current and/or power dissipation. The device switches into a constant-current mode at approximately 350 mA; further load reduces the output voltage instead of increasing the output current. The thermal protection shuts the regulator off if the junction temperature rises above 170°C. Recovery is automatic when the junction temperature drops approximately 20°C below the high temperature trip point. The PMOS pass element includes a back diode that safely conducts reverse current when the input voltage level drops below the output voltage level.

A typical application circuit is shown in [Figure 18](#).

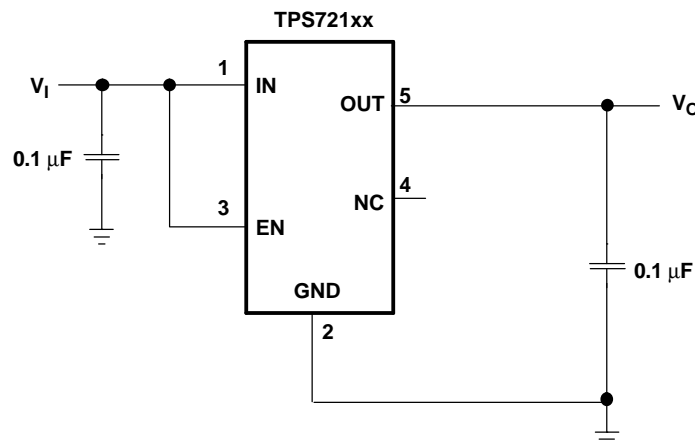

Figure 18. Typical Application Circuit

DUAL SUPPLY APPLICATION

In portable, battery-powered electronics, separate power rails for the DSP or microcontroller core voltage, $V_{(CORE)}$, and I/O peripherals (V_{IO}) are usually necessary. The TPS721xx family of LDO linear regulators is ideal for providing $V_{(CORE)}$ for the DSP or microcontroller. As shown in [Figure 19](#), two AAA batteries provide an input voltage to a boost converter and the TPS72115 LDO linear regulator. The batteries combine input voltage ranges from 3.0 V down to 1.8 V near the end of their useful lives. Therefore, a boost converter is necessary to provide the typical 3.3 V needed for V_{IO} , and the TPS72115 linear regulator provides a regulated $V_{(CORE)}$ voltage, which in this example is 1.5 V. Although there is no explicit circuitry to perform power-up sequencing of first $V_{(CORE)}$ then V_{IO} , the output of the linear regulator reaches its regulated voltage much faster (< 400 μ s) than the output of any switching type boost converter due to the inherent slow start up of those types of converters. Assuming a boost converter with minimum V_I of 1.8 V is appropriately chosen, this power supply solution can be used over the entire life of the two off-the-shelf AAA batteries. Thus, this solution is very efficient and the design time and overall cost of the solution is minimized.

APPLICATION INFORMATION (continued)

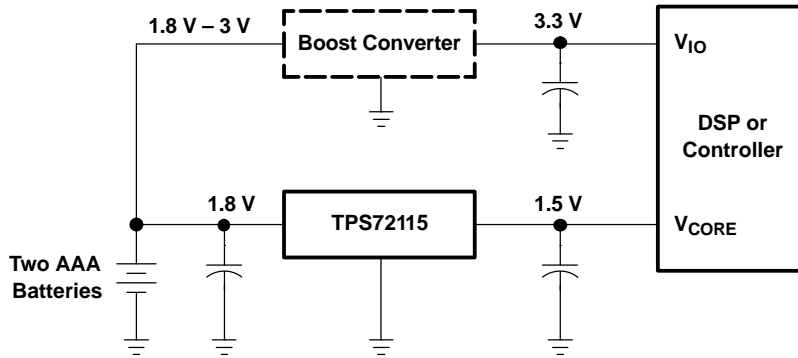

Figure 19. Dual Supply Application Circuit

EXTERNAL CAPACITOR REQUIREMENTS

A 0.1- μ F ceramic bypass capacitor is required on both the input and output for stability. Larger capacitors improve transient response, noise rejection, and ripple rejection. A higher value electrolytic input capacitor may be necessary if large, fast rise time load transient are anticipated, and/or there is significant input resistance from the device to the input power supply.

POWER DISSIPATION AND JUNCTION TEMPERATURE

Specified regulator operation is assured to a junction temperature of 125°C; the maximum junction temperature allowable without damaging the device is 150°C. This restriction limits the power dissipation the regulator can handle in any given application. To ensure the junction temperature is within acceptable limits, calculate the maximum allowable dissipation, $P_{D(max)}$, and the actual dissipation, P_D , which must be less than or equal to $P_{D(max)}$.

The maximum-power-dissipation limit is determined using Equation 1 :

$$P_{D(max)} = \frac{T_{Jmax} - T_A}{R_{\theta JA}} \quad (1)$$

Where:

- T_{Jmax} is the maximum allowable junction temperature.
- $R_{\theta JA}$ is the thermal resistance junction-to-ambient for the package; see the package dissipation rating table.
- T_A is the ambient temperature.

The regulator dissipation is calculated using Equation 2:

$$P_D = (V_I - V_O) \times I_O \quad (2)$$

Power dissipation resulting from quiescent current is negligible.

PROGRAMMING THE TPS72101 ADJUSTABLE LDO REGULATOR

The output voltage of the TPS72101 adjustable regulator is programmed using an external resistor divider as shown in Figure 20. The output voltage is calculated using Equation 3:

$$V_O = V_{ref} \times \left(1 + \frac{R1}{R2}\right) \quad (3)$$

Where:

- $V_{ref} = 1.225$ V typ (the internal reference voltage)

APPLICATION INFORMATION (continued)

Resistors R1 and R2 should be chosen for approximately 10- μ A divider current. Lower value resistors can be used but offer no inherent advantage and waste more power. Higher values should be avoided, as leakage currents at FB increase the output voltage error. The recommended design procedure is to choose R2 = 30.1 k Ω to set the divider current at 10 μ A and then calculate R1 using Equation 4:

$$R1 = \left(\frac{V_O}{V_{ref}} - 1 \right) \times R2 \quad (4)$$

Where:

- $V_{ref} = 1.225$ V.

OUTPUT VOLTAGE PROGRAMMING GUIDE		
OUTPUT VOLTAGE (V)	DIVIDER RESISTANCE (k Ω) ¹	
	R1	R2
2.5	127	121

Note (1): 1% values shown.

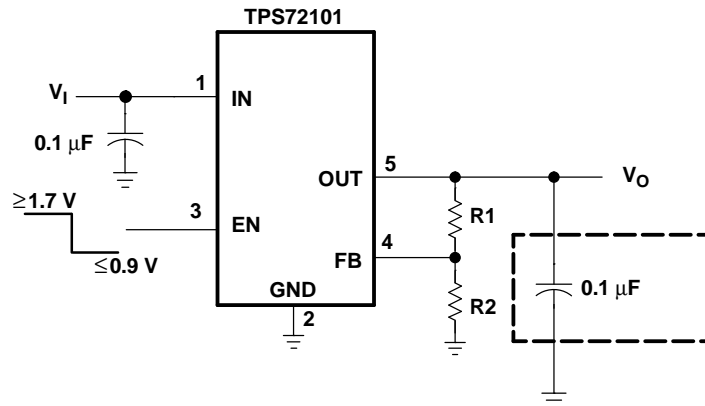

Figure 20. TPS72101 Adjustable LDO Regulator Programming

REGULATOR PROTECTION

The TPS721xx pass element has a built-in back diode that safely conducts reverse current when the input voltage drops below the output voltage (for example, during power down). Current is conducted from the output to the input and is not internally limited. If extended reverse voltage is anticipated, external limiting might be appropriate.

The TPS721xx also features internal current limiting and thermal protection. During normal operation, the TPS721xx limits output current to approximately 350 mA. When current limiting engages, the output voltage scales back linearly until the overcurrent condition ends. While current limiting is designed to prevent gross device failure, care should be taken not to exceed the power dissipation ratings of the package. If the temperature of the device exceeds 170°C, thermal-protection circuitry shuts it down. Once the device has cooled down to below 150°C, regulator operation resumes.

PACKAGING INFORMATION

Orderable Device	Status ⁽¹⁾	Package Type	Package Drawing	Pins	Package Qty	Eco Plan ⁽²⁾	Lead/Ball Finish	MSL Peak Temp ⁽³⁾
TPS72101DBVR	ACTIVE	SOT-23	DBV	5	3000	Green (RoHS & no Sb/Br)	CU NIPDAU	Level-1-260C-UNLIM
TPS72101DBVRG4	ACTIVE	SOT-23	DBV	5	3000	Green (RoHS & no Sb/Br)	CU NIPDAU	Level-1-260C-UNLIM
TPS72101DBVT	ACTIVE	SOT-23	DBV	5	250	Green (RoHS & no Sb/Br)	CU NIPDAU	Level-1-260C-UNLIM
TPS72101DBVTG4	ACTIVE	SOT-23	DBV	5	250	Green (RoHS & no Sb/Br)	CU NIPDAU	Level-1-260C-UNLIM
TPS72115DBVR	ACTIVE	SOT-23	DBV	5	3000	Green (RoHS & no Sb/Br)	CU NIPDAU	Level-1-260C-UNLIM
TPS72115DBVRG4	ACTIVE	SOT-23	DBV	5	3000	Green (RoHS & no Sb/Br)	CU NIPDAU	Level-1-260C-UNLIM
TPS72115DBVT	ACTIVE	SOT-23	DBV	5	250	Green (RoHS & no Sb/Br)	CU NIPDAU	Level-1-260C-UNLIM
TPS72115DBVTG4	ACTIVE	SOT-23	DBV	5	250	Green (RoHS & no Sb/Br)	CU NIPDAU	Level-1-260C-UNLIM
TPS72116DBVR	ACTIVE	SOT-23	DBV	5	3000	Green (RoHS & no Sb/Br)	CU NIPDAU	Level-1-260C-UNLIM
TPS72116DBVRG4	ACTIVE	SOT-23	DBV	5	3000	Green (RoHS & no Sb/Br)	CU NIPDAU	Level-1-260C-UNLIM
TPS72116DBVT	ACTIVE	SOT-23	DBV	5	250	Green (RoHS & no Sb/Br)	CU NIPDAU	Level-1-260C-UNLIM
TPS72116DBVTG4	ACTIVE	SOT-23	DBV	5	250	Green (RoHS & no Sb/Br)	CU NIPDAU	Level-1-260C-UNLIM
TPS72118DBVR	ACTIVE	SOT-23	DBV	5	3000	Green (RoHS & no Sb/Br)	CU NIPDAU	Level-1-260C-UNLIM
TPS72118DBVRG4	ACTIVE	SOT-23	DBV	5	3000	Green (RoHS & no Sb/Br)	CU NIPDAU	Level-1-260C-UNLIM
TPS72118DBVT	ACTIVE	SOT-23	DBV	5	250	Green (RoHS & no Sb/Br)	CU NIPDAU	Level-1-260C-UNLIM
TPS72118DBVTG4	ACTIVE	SOT-23	DBV	5	250	Green (RoHS & no Sb/Br)	CU NIPDAU	Level-1-260C-UNLIM

⁽¹⁾ The marketing status values are defined as follows:

ACTIVE: Product device recommended for new designs.

LIFEBUY: TI has announced that the device will be discontinued, and a lifetime-buy period is in effect.

NRND: Not recommended for new designs. Device is in production to support existing customers, but TI does not recommend using this part in a new design.

PREVIEW: Device has been announced but is not in production. Samples may or may not be available.

OBSELETE: TI has discontinued the production of the device.

⁽²⁾ Eco Plan - The planned eco-friendly classification: Pb-Free (RoHS), Pb-Free (RoHS Exempt), or Green (RoHS & no Sb/Br) - please check <http://www.ti.com/productcontent> for the latest availability information and additional product content details.

TBD: The Pb-Free/Green conversion plan has not been defined.

Pb-Free (RoHS): TI's terms "Lead-Free" or "Pb-Free" mean semiconductor products that are compatible with the current RoHS requirements for all 6 substances, including the requirement that lead not exceed 0.1% by weight in homogeneous materials. Where designed to be soldered at high temperatures, TI Pb-Free products are suitable for use in specified lead-free processes.

Pb-Free (RoHS Exempt): This component has a RoHS exemption for either 1) lead-based flip-chip solder bumps used between the die and package, or 2) lead-based die adhesive used between the die and leadframe. The component is otherwise considered Pb-Free (RoHS compatible) as defined above.

Green (RoHS & no Sb/Br): TI defines "Green" to mean Pb-Free (RoHS compatible), and free of Bromine (Br) and Antimony (Sb) based flame retardants (Br or Sb do not exceed 0.1% by weight in homogeneous material)

⁽³⁾ MSL, Peak Temp. -- The Moisture Sensitivity Level rating according to the JEDEC industry standard classifications, and peak solder temperature.

Important Information and Disclaimer:The information provided on this page represents TI's knowledge and belief as of the date that it is provided. TI bases its knowledge and belief on information provided by third parties, and makes no representation or warranty as to the accuracy of such information. Efforts are underway to better integrate information from third parties. TI has taken and continues to take reasonable steps to provide representative and accurate information but may not have conducted destructive testing or chemical analysis on incoming materials and chemicals. TI and TI suppliers consider certain information to be proprietary, and thus CAS numbers and other limited information may not be available for release.

In no event shall TI's liability arising out of such information exceed the total purchase price of the TI part(s) at issue in this document sold by TI to Customer on an annual basis.

OTHER QUALIFIED VERSIONS OF TPS72118 :

- Enhanced Product: [TPS72118-EP](#)

NOTE: Qualified Version Definitions:

- Enhanced Product - Supports Defense, Aerospace and Medical Applications

TAPE AND REEL INFORMATION



QUADRANT ASSIGNMENTS FOR PIN 1 ORIENTATION IN TAPE



*All dimensions are nominal

Device	Package Type	Package Drawing	Pins	SPQ	Reel Diameter (mm)	Reel Width W1 (mm)	A0 (mm)	B0 (mm)	K0 (mm)	P1 (mm)	W (mm)	Pin1 Quadrant
TPS72101DBVR	SOT-23	DBV	5	3000	179.0	8.4	3.2	3.2	1.4	4.0	8.0	Q3
TPS72101DBVT	SOT-23	DBV	5	250	179.0	8.4	3.2	3.2	1.4	4.0	8.0	Q3
TPS72115DBVR	SOT-23	DBV	5	3000	179.0	8.4	3.2	3.2	1.4	4.0	8.0	Q3
TPS72115DBVT	SOT-23	DBV	5	250	179.0	8.4	3.2	3.2	1.4	4.0	8.0	Q3
TPS72116DBVR	SOT-23	DBV	5	3000	179.0	8.4	3.2	3.2	1.4	4.0	8.0	Q3
TPS72116DBVT	SOT-23	DBV	5	250	179.0	8.4	3.2	3.2	1.4	4.0	8.0	Q3
TPS72118DBVR	SOT-23	DBV	5	3000	179.0	8.4	3.2	3.2	1.4	4.0	8.0	Q3
TPS72118DBVT	SOT-23	DBV	5	250	179.0	8.4	3.2	3.2	1.4	4.0	8.0	Q3

TAPE AND REEL BOX DIMENSIONS



*All dimensions are nominal

Device	Package Type	Package Drawing	Pins	SPQ	Length (mm)	Width (mm)	Height (mm)
TPS72101DBVR	SOT-23	DBV	5	3000	195.0	200.0	45.0
TPS72101DBVT	SOT-23	DBV	5	250	195.0	200.0	45.0
TPS72115DBVR	SOT-23	DBV	5	3000	195.0	200.0	45.0
TPS72115DBVT	SOT-23	DBV	5	250	195.0	200.0	45.0
TPS72116DBVR	SOT-23	DBV	5	3000	195.0	200.0	45.0
TPS72116DBVT	SOT-23	DBV	5	250	195.0	200.0	45.0
TPS72118DBVR	SOT-23	DBV	5	3000	195.0	200.0	45.0
TPS72118DBVT	SOT-23	DBV	5	250	195.0	200.0	45.0

DBV (R-PDSO-G5)

PLASTIC SMALL-OUTLINE PACKAGE

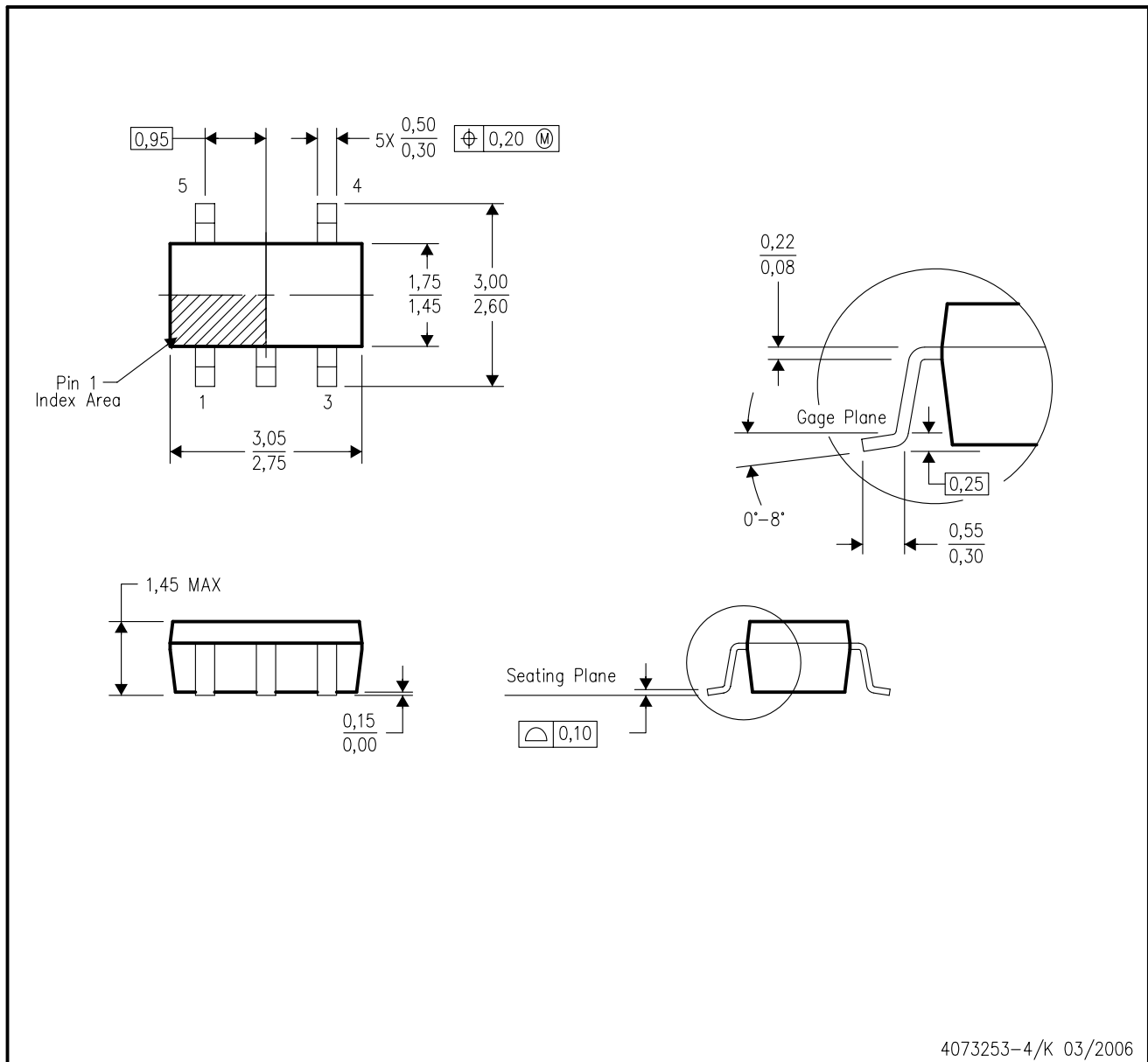

- NOTES:
- A. All linear dimensions are in millimeters.
 - B. This drawing is subject to change without notice.
 - C. Body dimensions do not include mold flash or protrusion. Mold flash and protrusion shall not exceed 0.15 per side.
 - D. Falls within JEDEC MO-178 Variation AA.

IMPORTANT NOTICE

Texas Instruments Incorporated and its subsidiaries (TI) reserve the right to make corrections, modifications, enhancements, improvements, and other changes to its products and services at any time and to discontinue any product or service without notice. Customers should obtain the latest relevant information before placing orders and should verify that such information is current and complete. All products are sold subject to TI's terms and conditions of sale supplied at the time of order acknowledgment.

TI warrants performance of its hardware products to the specifications applicable at the time of sale in accordance with TI's standard warranty. Testing and other quality control techniques are used to the extent TI deems necessary to support this warranty. Except where mandated by government requirements, testing of all parameters of each product is not necessarily performed.

TI assumes no liability for applications assistance or customer product design. Customers are responsible for their products and applications using TI components. To minimize the risks associated with customer products and applications, customers should provide adequate design and operating safeguards.

TI does not warrant or represent that any license, either express or implied, is granted under any TI patent right, copyright, mask work right, or other TI intellectual property right relating to any combination, machine, or process in which TI products or services are used. Information published by TI regarding third-party products or services does not constitute a license from TI to use such products or services or a warranty or endorsement thereof. Use of such information may require a license from a third party under the patents or other intellectual property of the third party, or a license from TI under the patents or other intellectual property of TI.

Reproduction of TI information in TI data books or data sheets is permissible only if reproduction is without alteration and is accompanied by all associated warranties, conditions, limitations, and notices. Reproduction of this information with alteration is an unfair and deceptive business practice. TI is not responsible or liable for such altered documentation. Information of third parties may be subject to additional restrictions.

Resale of TI products or services with statements different from or beyond the parameters stated by TI for that product or service voids all express and any implied warranties for the associated TI product or service and is an unfair and deceptive business practice. TI is not responsible or liable for any such statements.

TI products are not authorized for use in safety-critical applications (such as life support) where a failure of the TI product would reasonably be expected to cause severe personal injury or death, unless officers of the parties have executed an agreement specifically governing such use. Buyers represent that they have all necessary expertise in the safety and regulatory ramifications of their applications, and acknowledge and agree that they are solely responsible for all legal, regulatory and safety-related requirements concerning their products and any use of TI products in such safety-critical applications, notwithstanding any applications-related information or support that may be provided by TI. Further, Buyers must fully indemnify TI and its representatives against any damages arising out of the use of TI products in such safety-critical applications.

TI products are neither designed nor intended for use in military/aerospace applications or environments unless the TI products are specifically designated by TI as military-grade or "enhanced plastic." Only products designated by TI as military-grade meet military specifications. Buyers acknowledge and agree that any such use of TI products which TI has not designated as military-grade is solely at the Buyer's risk, and that they are solely responsible for compliance with all legal and regulatory requirements in connection with such use.

TI products are neither designed nor intended for use in automotive applications or environments unless the specific TI products are designated by TI as compliant with ISO/TS 16949 requirements. Buyers acknowledge and agree that, if they use any non-designated products in automotive applications, TI will not be responsible for any failure to meet such requirements.

Following are URLs where you can obtain information on other Texas Instruments products and application solutions:

Products

Amplifiers	amplifier.ti.com
Data Converters	dataconverter.ti.com
DSP	dsp.ti.com
Clocks and Timers	www.ti.com/clocks
Interface	interface.ti.com
Logic	logic.ti.com
Power Mgmt	power.ti.com
Microcontrollers	microcontroller.ti.com
RFID	www.ti-rfid.com
RF/IF and ZigBee® Solutions	www.ti.com/lprf

Applications

Audio	www.ti.com/audio
Automotive	www.ti.com/automotive
Broadband	www.ti.com/broadband
Digital Control	www.ti.com/digitalcontrol
Medical	www.ti.com/medical
Military	www.ti.com/military
Optical Networking	www.ti.com/opticalnetwork
Security	www.ti.com/security
Telephony	www.ti.com/telephony
Video & Imaging	www.ti.com/video
Wireless	www.ti.com/wireless

Mailing Address: Texas Instruments, Post Office Box 655303, Dallas, Texas 75265
Copyright © 2008, Texas Instruments Incorporated